



# Cambridge O Level

---

**PHYSICS****5054/12**

Paper 1 Multiple Choice

**May/June 2021****1 hour**

You must answer on the multiple choice answer sheet.

You will need: Multiple choice answer sheet  
Soft clean eraser  
Soft pencil (type B or HB is recommended)

---

**INSTRUCTIONS**

- There are **forty** questions on this paper. Answer **all** questions.
- For each question there are four possible answers **A, B, C** and **D**. Choose the **one** you consider correct and record your choice in soft pencil on the multiple choice answer sheet.
- Follow the instructions on the multiple choice answer sheet.
- Write in soft pencil.
- Write your name, centre number and candidate number on the multiple choice answer sheet in the spaces provided unless this has been done for you.
- Do **not** use correction fluid.
- Do **not** write on any bar codes.
- You may use a calculator.

**INFORMATION**

- The total mark for this paper is 40.
- Each correct answer will score one mark.
- Any rough working should be done on this question paper.

---

This document has **16** pages. Any blank pages are indicated.

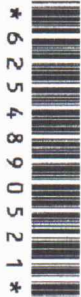

- 1 A student determines the circumference of a football.

Which instrument gives a reading that is the circumference of the football?

- A calipers  
B micrometer  
C rule

~~D~~ tape → Can be wound around the circumference.

- 2 A coin falls from rest through the air and eventually reaches a constant speed.

There is a resultant force acting on the coin due to the two forces P and Q shown in the diagram.

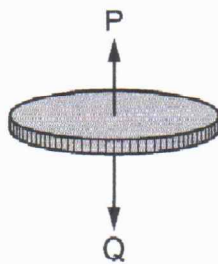

What happens to force P and what happens to the resultant force before the coin reaches constant speed?

	force P	resultant force
A	decreases	increases
B	decreases	decreases
<del>C</del>	increases	decreases
D	increases	increases

Drag force <sup>-P</sup> increases with speed and the resultant force is continuously decreasing

3 The diagrams show the forces acting on four identical solid blocks.

Each arrow represents a force of 20 N.

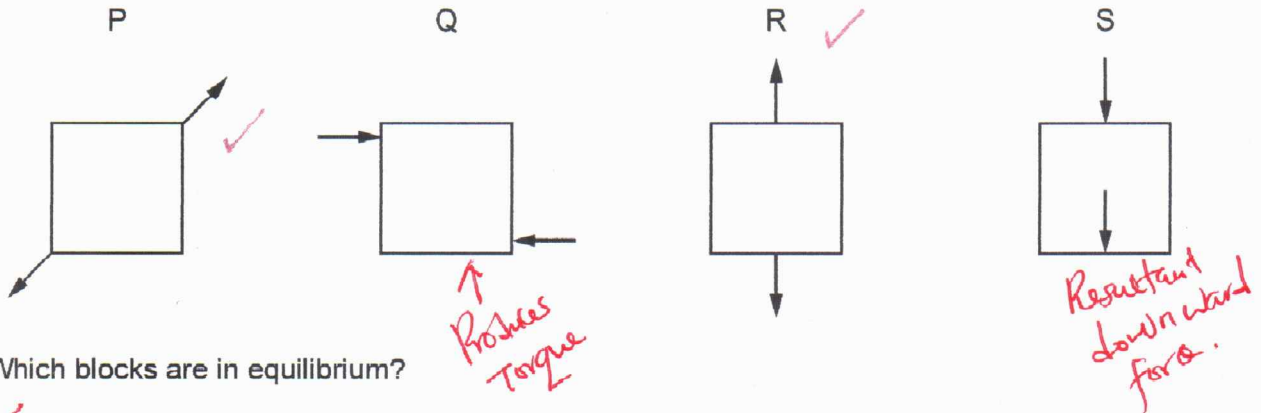

Which blocks are in equilibrium?

- ~~A~~ P and R only
- B Q and S only
- C P, Q and R only
- D P, Q, R and S

4 A student lists three changes that affect the stopping distance of a car.

- 1 increasing the braking force  $\times \rightarrow$  will stop the car sooner
- 2 increasing the friction between the tyres and the road  $\times \rightarrow$  will stop the car sooner.
- 3 increasing the speed of the car

Which change or changes increase the stopping distance?

- A 1 and 2
- B 1 and 3
- C 1 only
- ~~D~~ 3 only

5 The diagram shows a satellite orbiting a planet at a steady speed.

In which direction does the resultant force act on the satellite?

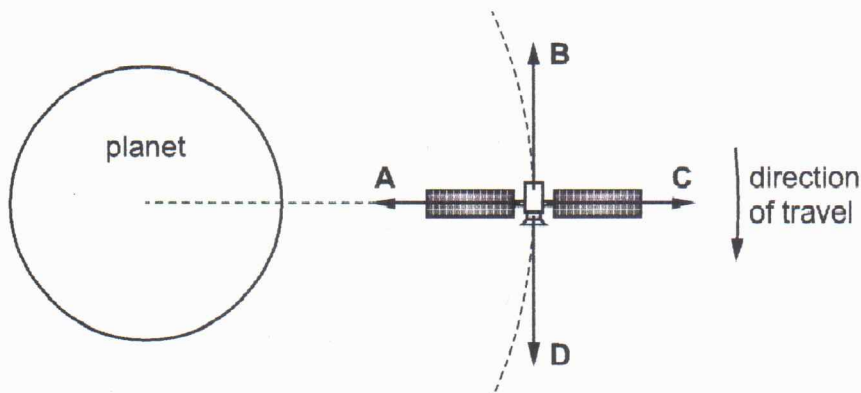

$\rightarrow$  "Centre seeking force"  
Centripetal force  
not to scale  
 $\downarrow$   
Keeping the satellite in the circular motion.

- 6 The gravitational field strength in space is smaller than on the Earth's surface.

A rocket is used to launch a satellite from the Earth's surface into space.

How are the mass and the weight of the satellite affected as the satellite moves away from the surface of the Earth and into space?

- A Both the mass and the weight are unaffected.  
 B The mass decreases and the weight decreases.  
 C The mass increases and the weight is unaffected.  
~~D~~ The mass is unaffected and the weight decreases.

↓  
 Mass is a constant that does not change.  
 Weight changes with gravitational field strength which is not a constant.

- 7 Air is trapped in a cylinder by a piston.

The piston is moved inwards so that the volume of the air reduces.

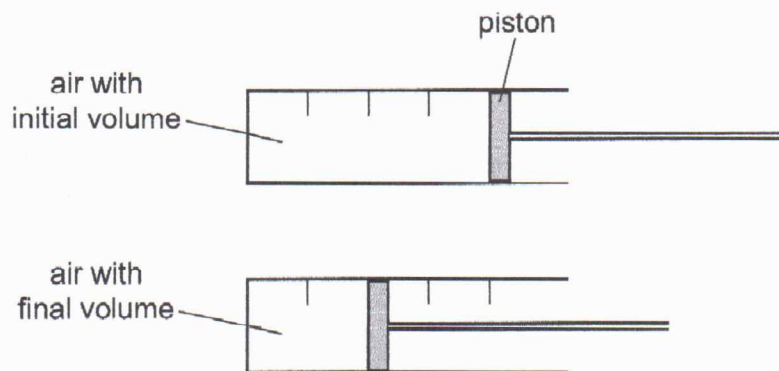

The density of the air in the syringe at the initial volume is  $0.0012 \text{ g/cm}^3$ .

What is the density of the air in the syringe at the final volume?

- A  $0.0006 \text{ g/cm}^3$   
 B  $0.0012 \text{ g/cm}^3$   
~~C~~  $0.0024 \text{ g/cm}^3$   
 D  $0.0048 \text{ g/cm}^3$

$\rho = \frac{m}{V}$   
 $\rho$  is inversely proportional to volume, so it will be more than  $0.0012$ .  
 When volume halves, density doubles

5

8 Some forces are applied at different distances from a pivot.

Which diagram shows the force that produces the largest moment about the pivot?

$M = F \times d$  → Larger force and distance produces largest moment.

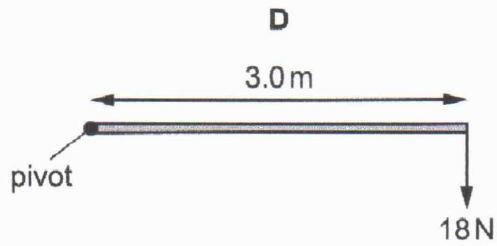
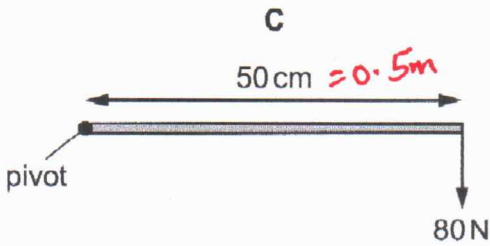
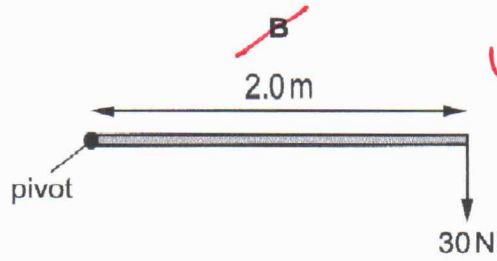
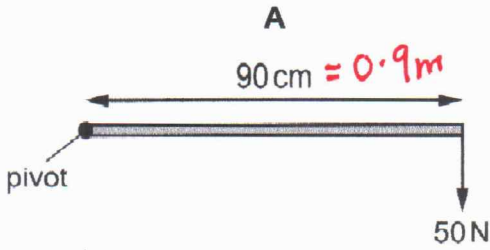

not to scale

9 The diagram shows a children's wooden play tower.

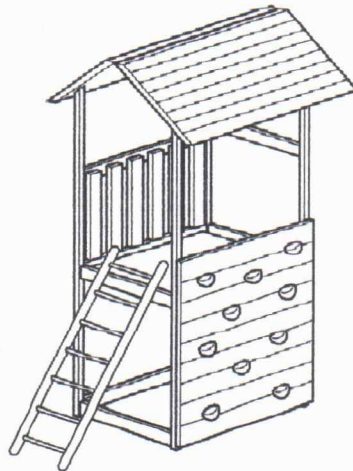

Which change to the tower makes it more stable?

- A making the tower narrower
- B making the tower taller
- ~~C lowering the centre of mass~~
- D raising the centre of mass

Lower G.O.M increase stability and also broader base.

10 Where on the graph is the limit of proportionality for an elastic solid?

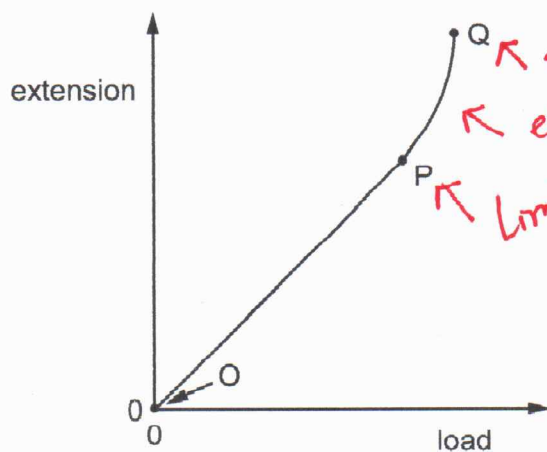

- A between O and P
- ~~B at P~~
- C between P and Q
- D at Q

11 A weight of 2.0N is hung from a spring. The extension produced is 6.0 cm. The 2.0N weight is removed and an 8.0N weight is hung from the spring. The spring does not pass its limit of proportionality.  $\Delta x = \frac{F}{k}$  and  $k = \frac{F}{\Delta x} \Rightarrow \frac{2}{6} = 0.333 \approx \frac{1}{3}$   $\Delta x = \frac{8.0}{0.333} = 24 \text{ cm}$ .

What is the new extension of the spring?

- A 6.0 cm
- ~~B 24 cm~~
- C 36 cm
- D 48 cm

12 An object is placed at a depth  $d$  below the surface of a liquid of density  $\rho$ .

Pressure in fluids  
 $P = h \times \rho \times g$ .

On which expression does the pressure on the object depend?

- A  $d + \rho$
- ~~B  $d \times \rho$~~
- C  $d \div \rho$
- D  $\rho \div d$

13 The diagram shows the dimensions of a box of mass  $M$  and weight  $W$  at rest on a table.

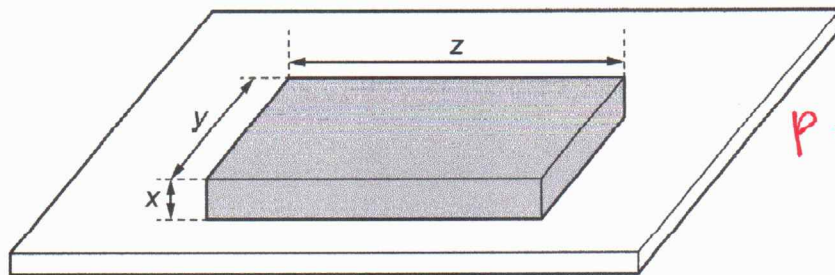

Pressure =  $\frac{\text{Force} = Mg}{\text{Area}}$   
 $P = \frac{W}{yz}$   
Cross section area in contact with the surface.

What is the pressure on the table due to the box?

- A  $\frac{M}{xyz}$
- B  $\frac{M}{yz}$
- C  $\frac{W}{xyz}$
- ~~D  $\frac{W}{yz}$~~

- 14 Which graph shows the relationship between the pressure and the volume of a fixed mass of gas at constant temperature?

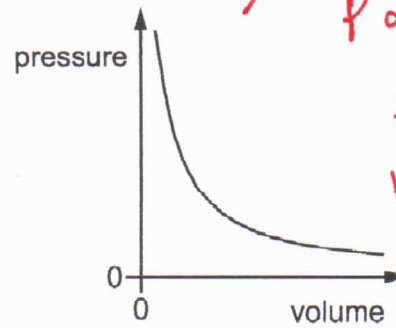
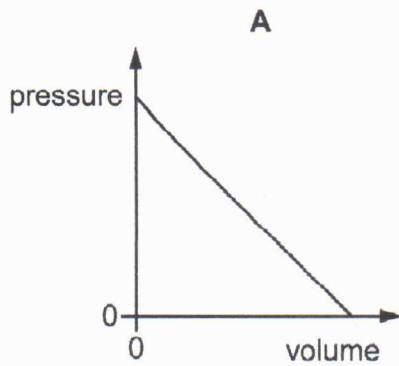

$P \propto \frac{1}{V}$   
 P is inversely proportional to V. Their relationship is non-linear.

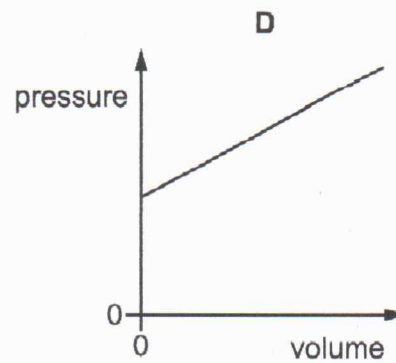
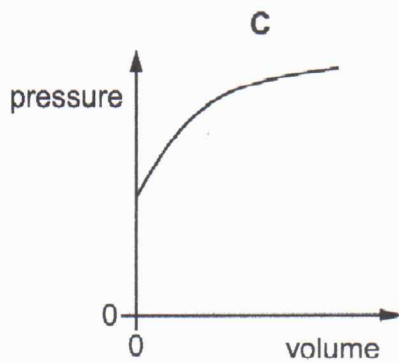

- 15 The work done by a force  $F$  on a body is calculated by multiplying  $F$  by a quantity  $q$ .

What is  $q$ ?

Work done = force  $\times$  distance travelled in the direction of force

- ~~A~~ the distance travelled in the direction of the force  
 B the distance travelled perpendicular to the direction of the force  
 C the velocity in the direction of the force  
 D the velocity in the direction perpendicular to the force

- 16 A girl lifts an object of mass 1.0 kg from the floor and puts it on a ledge 2.0 m above the floor.

How much potential energy is gained by the object?

$$\begin{aligned} G.P.E &= m \times g \times h \\ &= 1 \times 10 \times 2 \\ &= 20 \end{aligned}$$

[gravitational field strength  $g = 10 \text{ N/kg}$ ]

- A 2.0 J      B 5.0 J      C 10 J      ~~D 20 J~~

17 A copper rod is heated at one end.

Which statement describes how heat transfer occurs in the copper?

*Conduction occurs by heat transfer by the free electron and vibration of ions/lattice.*

- A Energetic copper molecules move from the cooler end to the hotter end.
- B Energetic copper molecules move from the hotter end to the cooler end.
- C Energetic free electrons move from the cooler end to the hotter end.
- ~~D Energetic free electrons move from the hotter end to the cooler end.~~

18 Which heat transfer processes do **not** require a medium?

- A conduction only
- B convection only
- ~~C radiation only~~
- D conduction and radiation

*Thermal Energy transfer by means of an electromagnetic radiation known as infrared.*

19 The list shows four physical properties.

mass                      resistance                      voltage                      volume

*← e.g. in thermistor*

*— e.g. in alcohol or mercury thermometers*

How many of these properties can be used to measure temperature?

- A 1
- B 2
- ~~C 3~~
- D 4

20 The diagram shows a clinical thermometer.

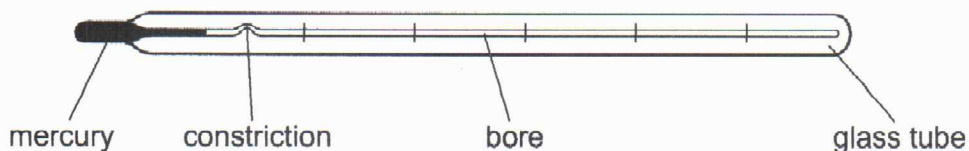

Which factor affects the sensitivity of the thermometer?

- A the constriction
- ~~B the diameter of the bore~~
- C the length of the glass tube
- D the thickness of the glass tube

*→ The thinner it is, the more sensitive it is.*

21 Which statement about the thermal expansion of solids, liquids and gases is correct?

- A Liquids do not expand.
- B Liquids expand more than gases but less than solids.
- ~~C Liquids expand more than solids but less than gases.~~
- D Liquids expand the same amount as solids but less than gases.

*The bigger the space between particles between the higher the expansion.*



22 Which row describes the shape of a liquid and the arrangement of its molecules?

	shape	arrangement of molecules
A	fixed	not regular
B	fixed	regular
<del>C</del>	takes shape of container	not regular
D	takes shape of container	regular

23 Air in a sealed container of fixed volume is heated.

The pressure of the air increases.

How do the molecules of air cause this increase in pressure?

- A The molecules expand and push on the container with a greater force.
- B The molecules move at the same speed and hit the container with a greater force.
- ~~C~~ The molecules move faster and hit the container more often.
- D The molecules move further apart and hit the container more often.

24 A ray of red light in air enters a semi-circular block.

Which diagram shows the partial reflection and the refraction of the ray?

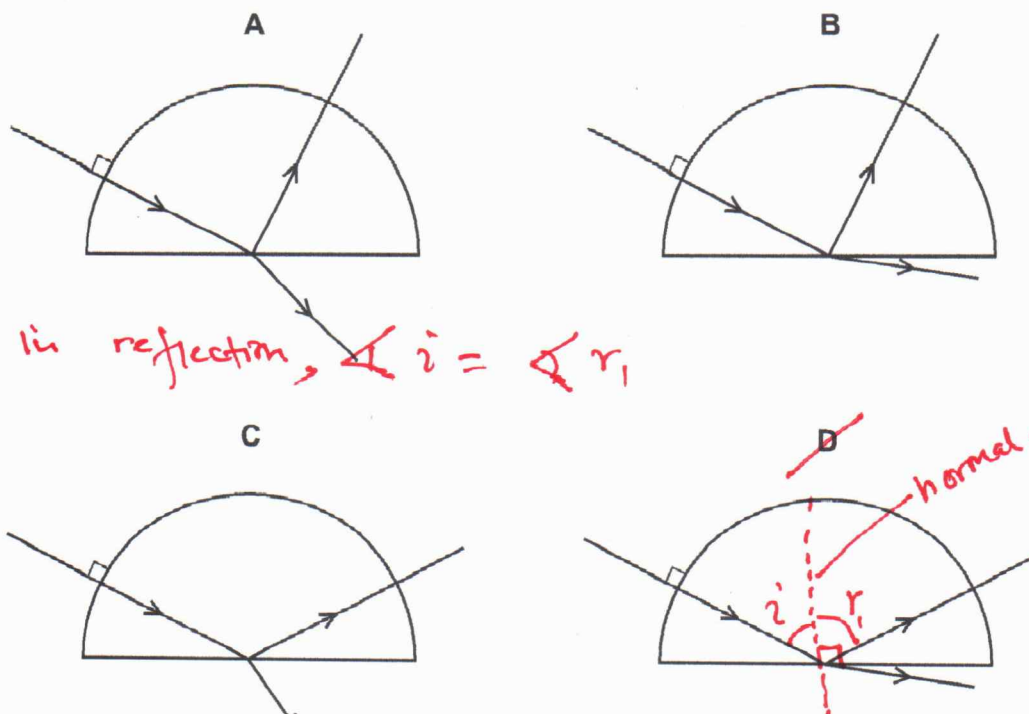

When a ray of light is incident on a surface at  $90^\circ$  it does not bend, as it moves from more dense to less dense medium it bends away from the normal.

25 An object of height 1.5 cm is placed in front of a converging lens of focal length 2.0 cm.

The arrangement is shown on the full-scale ray diagram.

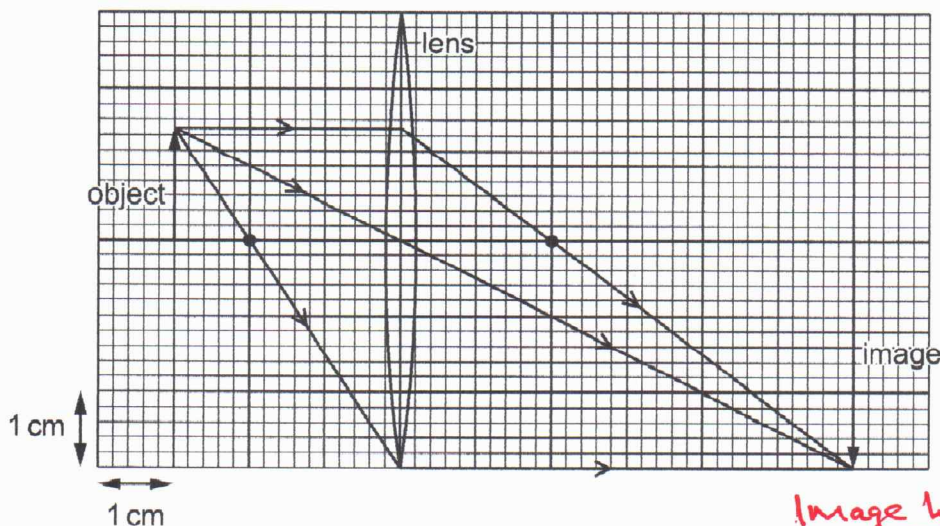

*Image height = 3.0*  
*Object height = 1.5*  
*= 2.*

What is the linear magnification produced by the lens?

- A 2.0
- B 3.0
- C 4.0
- D 6.0

26 In which optical instrument is the distance between the object and the lens less than the focal length of the lens?

- A camera
- B magnifying glass
- C photographic enlarger
- D projector

27 Which two waves are components of the electromagnetic spectrum?

- A light and sound
  - B water waves and infrared
  - C ultrasound and ultraviolet
  - D X-rays and microwaves
- Radio waves*  
*Microwaves*  
*Infrared*  
*Visible light*  
*UV light*  
*X-rays*  
*Gamma rays*

28 The sound from a ship is reflected by a cliff. An echo is heard by a sailor on the ship 4.0 s after the sound is made. The speed of sound in air is 320 m/s.

How far from the cliff is the ship?

- A 160 m
- B 640 m
- C 1280 m
- D 2560 m

*Speed of sound =  $\frac{d}{t}$   $\Rightarrow d = \frac{s \times t}{2}$*   
*=  $\frac{320 \times 4}{2} = 640\text{m}$*

29 Students are asked for the uses of ultrasound.

Three suggested uses for ultrasound are:

- P cleaning jewellery ✓
- Q tanning on a sunbed ✗
- R obtaining an image of an unborn baby. ✓

Which suggestions are correct?

- A P and Q only ~~B~~ P and R only C Q and R only D P, Q and R

30 End X of a metal rod attracts the North pole of a compass needle.

Which statement about the rod is correct?

- A It is made of copper that is not initially magnetised.
- B It is made of copper with a South pole at X.
- ~~C~~ It is made of steel that is not initially magnetised.
- D It is made of steel with a North pole at X.

*if magnetised, the compass would point from north of steel to south.*

31 A positively charged rod is held close to an insulated metal sphere. The sphere is earthed as shown.

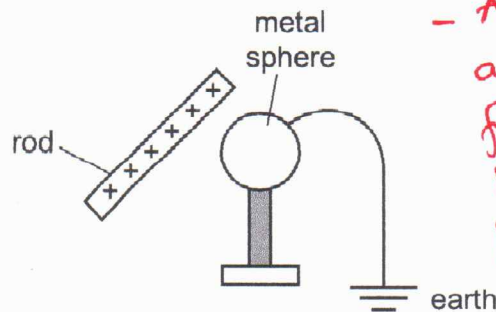

*- Attract negative charges and electrons moves from the ground to neutralize the repelled positive charges.*

The earth connection is removed and then the rod is removed.

Which diagram shows the charges on the sphere after the rod is removed?

*- After withdrawn the negative charges spread.*

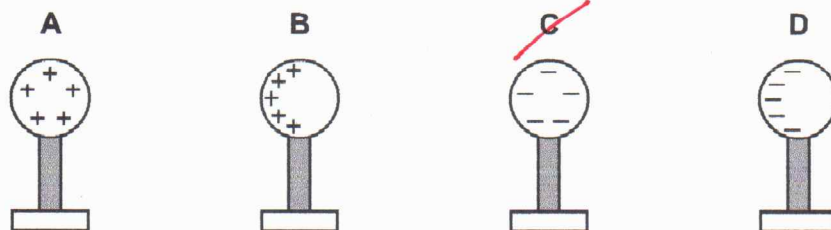

32 The diagram shows a circuit.

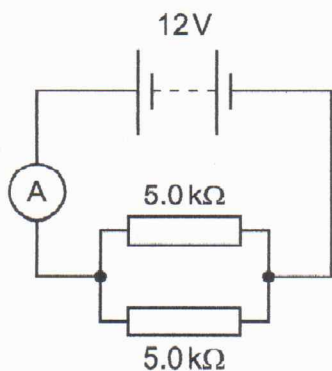

$$\frac{1}{R} = \frac{1}{5} + \frac{1}{5} = \frac{2}{5}$$

$$R = \frac{5}{2} \text{ k} = 2500$$

$$I = \frac{V}{R} = \frac{12}{2500} = 4.8 \times 10^{-3}$$

or 4.8 mA

The ammeter has four different range settings.

Which range setting gives a reading near the mid-point of the range?

- A 0–1 mA    ~~B 0–10 mA~~    C 0–1.0 A    D 0–10 A

33 In which example is the current 1.0 A?

- ~~A~~ a charge of 0.10 C passes through a resistor in 100 ms  $\rightarrow I = \frac{Q}{t} = \frac{0.1}{0.1} = 1$   
 B a 10 V lamp with input power 0.10 W  $\rightarrow I = \frac{P}{V} = \frac{0.1}{10} = 0.01$   
 C a resistor of resistance 0.50 Ω with a potential difference (p.d.) of 2.0 V across it  $\rightarrow I = \frac{V}{R} = \frac{2}{0.5} = 4 \text{ A}$   
 D two resistors with a current of 0.50 A connected in series  $\rightarrow 0.50 \text{ A on each resistor / the same.}$

34 Which graph shows the relationship between current and voltage for a filament lamp?

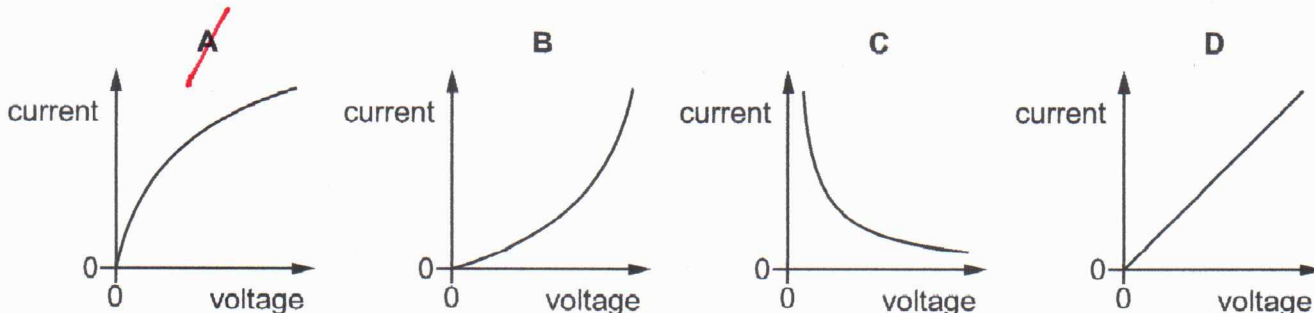

35 A 100 W lamp is switched on for five hours each day for three weeks.

The cost of one unit of electricity is \$0.24.

How much does it cost to run the lamp for this time?

- A \$0.36    B \$0.84    ~~C \$2.52~~    D \$25.20

1 unit = 1 kWh

$$100 \times 5 \times 7 \times 3 = 10500 \text{ Wh}$$

$$\frac{10500}{1000} = 10.5 \text{ kWh}$$

$$10.5 \times 0.24$$

- 36 A three-pin mains plug contains a fuse. A device with double insulation has a cable connected to the plug.

Which part of the plug is **not** connected to the cable?

*Double insulation eliminates*

A earth pin

*the need of Earth wire.*

B fuse

C live pin

D neutral pin

- 37 A trolley carrying a strong magnet rolls down a ramp at constant speed. It passes through a coil as shown.

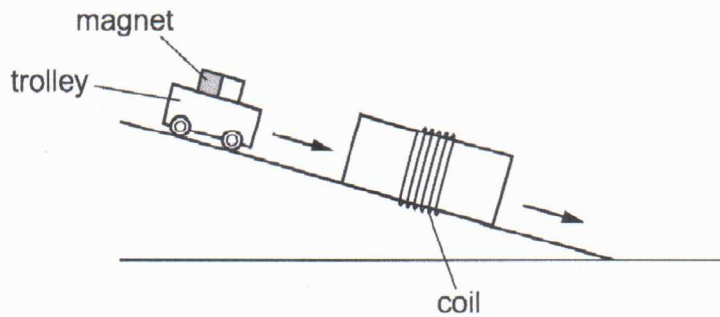

An electromotive force (e.m.f.) is induced in the coil. A graph of the e.m.f. against time is plotted.

The experiment is repeated with different coils and with a steeper ramp. The trolley moves at a greater constant speed on the steeper ramp.

Which graph is produced using the coil with the least number of turns and the steepest ramp? All graphs are drawn to the same scale.

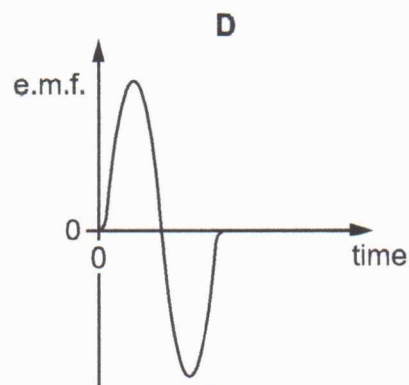
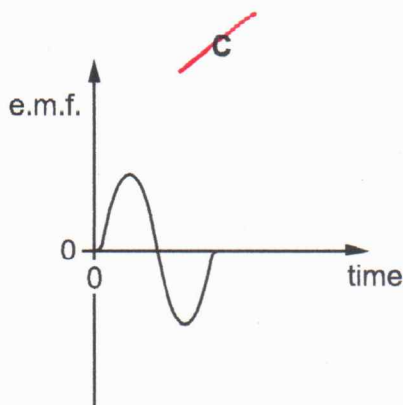
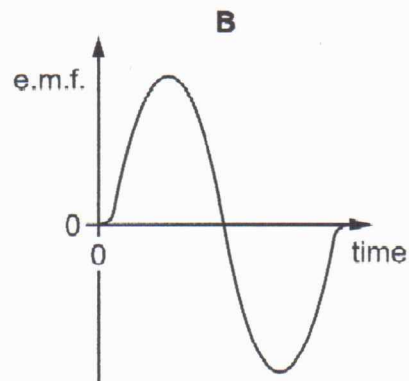
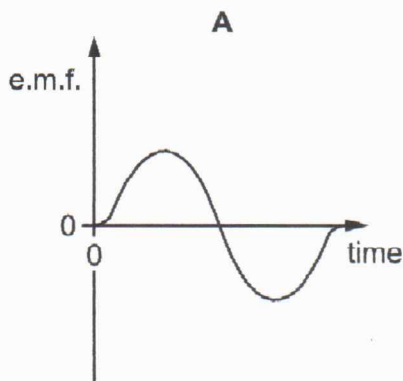

least turns - less e.m.f. - less amplitude.  
steep slope - high speed - higher frequency.

- 38 A student uses a transformer to light a filament lamp using a 230V a.c. supply. The lamp has a maximum voltage rating of 6.0V.

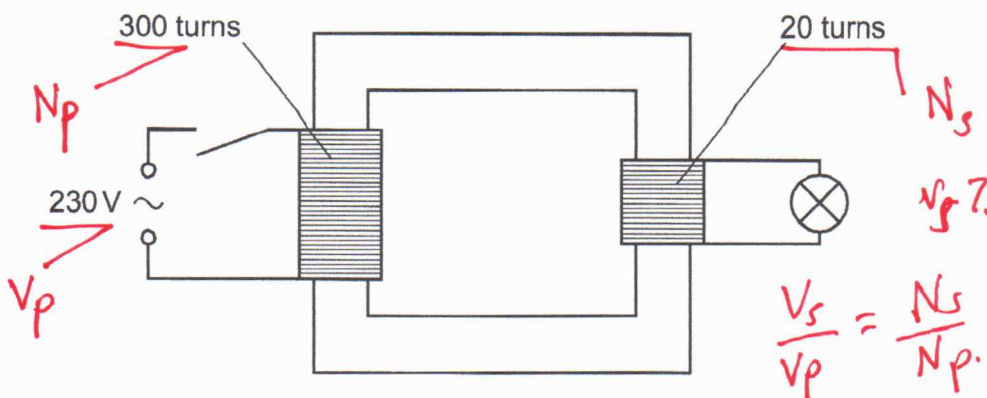

What happens when the circuit is switched on?

- A The lamp does not light at all.
- B The lamp lights at normal brightness.
- C The lamp lights dimly.
- D The lamp lights up brightly and then goes out.

Handwritten calculations:  

$$V_s = \frac{N_s}{N_p} \times V_p$$

$$= \frac{20}{300} \times 230 = 15.3V$$
 Too high the lamp must blow.

- 39 What does an alpha-particle consist of?

- A two electrons and four neutrons only
- B two protons and two neutrons only
- C two protons and four neutrons only
- D two protons, two electrons and two neutrons

Handwritten notes:  
 4 - nucleons = 2n + 2p.  
 2 - Proton number

- 40 The count rate from a radioactive source falls from 4000 counts per minute to 500 counts per minute in 72 minutes.

What is the half-life of the source?

- A 8 minutes
- B 9 minutes
- C 18 minutes
- D 24 minutes

Handwritten calculations:  

$$1 \cdot t_{1/2} = \frac{4000}{2} = 2000$$

$$2 \cdot t_{1/2} = \frac{2000}{2} = 1000$$

$$3 \cdot t_{1/2} = \frac{1000}{2} = 500$$
 Three half lives.  
 if  $3 t_{1/2} = 72 \text{ mins.}$   
 $1 t_{1/2} = ??$   
 $= \frac{72}{3} = 24 \text{ min.}$